

Standard and Optional Equipment

●=Std ○=Opt

Category	Description	SK380SRLC-7
Engine	ISUZU 6HK1 (Tier IV Final certified)	●
	Auto engine acceleration/deceleration	●
	Auto Idle Stop	●
Hydraulic system	3 work modes H, S, Eco	●
	Power boost	●
	Heavy lift mode	●
	Hydraulic Pressure Release	●
	Independent travel	●
	Swing priority	●
	Boom to arm regeneration	●
	Auto warm-up system	●
	Bi-direction (proportional hand control) and single-direction auxiliary hydraulics (nibbler and breaker)	●
	Rotation hydraulics with proportional hand control	○
	Hydraulic oil VG46	●
	Cabin	Air suspension seat with heat
10-inch color monitor		●
LED door light		●
Automatic climate control		●
Radio (AM/FM, AUX, USB, Bluetooth® and hands-free telephone)		●
12V power outlet		●
7 LED work lights: 2 on boom, 2 on cab front, 2 on rear counterweight, 1 on front right		●
Working equipment	Standard boom 20'4" {6.20 m}	●
	Standard HD arm 10'2" {3.10 m} with rock guard	●
	Long arm 12'0" {3.65 m}	○
Counter weight	Standard C/W 19,600 lb {8,900 kg} with swing flashers	●
Undercarriage	33.5" {850 mm} triple grouser shoe	●
	31.5" {800 mm} triple grouser shoe	○
	31.5" {800 mm} single grouser shoe	○
Safety	ROPS cab (ISO 12117-2:2008)	●
	Tilt opening top cab guard (Top guard level II ISO 10262:1998)	●
	Bar-type front guard (Front guard level II ISO 10262:1998)	○
	Mesh-type front guard (Front guard level I ISO 10262:1998)	○
	Engine emergency stop switch	●
	3-inch retractable seat belt	●
	Seatbelt indicator on display	●
	Travel alarm	●
	Swing flashers in counterweight	●
	Left and right side mirrors	●
	3-side 270-degree camera system	●
	Hose burst valve for boom and arm cylinder	○
	Others	Angled upper deck guards
Machine Guidance ready brackets		●
Quick coupler piping ready brackets		●
ISO to BHL pattern changer		●
Battery disconnect switch		●
KOMEXS Machine Monitoring		●
4 Year or 4,000 Hour Warranty		●
Single pedal travel		●

Note: Bluetooth® is a registered trademark of the Bluetooth SIG Inc.

Note: This catalog may contain attachments and optional equipment that are not available in your area. And it may contain photographs of machines with specifications that differ from those of machines sold in your areas. Please consult your nearest KOBELCO distributor for those items you require. Due to our policy of continuous product improvements all designs and specifications are subject to change without advance notice.

Copyright by KOBELCO CONSTRUCTION MACHINERY CO., LTD. No part of this catalog may be reproduced in any manner without notice.

KOBELCO CONSTRUCTION MACHINERY U.S.A. INC.

22350 Merchants Way, Katy, TX 77449
 Tel: 281-888-8430 Fax: 281-506-8713
 www.KOBELCO-USA.com

Inquiries To:

KOBELCO is the corporate mark used by Kobe Steel on a variety of products and in the names of a number of Kobe Steel Group companies.

Bulletin SK380SRLC-7 -NA-201-2304XXEX

KOBELCO

Hydraulic Excavator

-7 SERIES

SK380SRLC

Performance  Design

■ **Bucket Capacity:**

0.75–1.875 cu.yd. SAE

■ **Engine Power:**

265 hp {198 kW} @ 1,900 rpm
(SAE NET)

■ **Operating Weight:**

83,600 lb {37,900 kg} –84,700 lbs {38,400 kg}



Complies with the latest exhaust emission regulations





Performance Design

PERFORMANCE BY DESIGN

The next generation of KOBELCO excavators bring together superior performance and thoughtful design like never before. Performance enhancements offer greater efficiency and productivity along with increased power and speed. Design improvements provide the ultimate in comfort and control.

KOBELCO refuses to compromise, creating machines that meet every challenge.

SK380SR_{LC}

EXCEPTIONAL PERFORMANCE JUST GOT EVEN BETTER

Higher Efficiency, Plus a Tier IV Final Compliant Engine

The new SK380SR is equipped with a Isuzu Tier IV Final compliant engine, which has a higher torque value. This engine is fitted with a diesel oxidation catalyst (DOC) and an SCR device to control emissions without using a diesel particulate filter (DPF).



Model: ISUZU 6HK1

Rated Power Output

265 hp {**198** kW}/**1,900** rpm (SAE NET)



Short radius design occupies only one lane of highway

In addition to excellent lifting and digging performance, the SK380SR has adopted the attachment mode for a variety of tasks such as breaking and operates effectively even in narrow spaces as a single highway lane. Moreover, the cab permits operators to concentrate on work in a wide and comfortable space.



EXCELLENT LIFTING AND DIGGING PERFORMANCE IN NARROW SPACES

Drawbar Pulling Force (SAE J1309)

Excellent drawbar force lets you conquer rough terrain and slopes.

70,500 lbs {314 kN}

Lifting Capacity

27,540 lbs {12,490 kg}

(Ground level over front @20')

Heavy Lift

High hydraulic pressure (Heavy Lift) means greater lifting power, at close radius, allowing for smooth and steady operation while moving heavy objects.

Independent Travel

Automatic Independent Travel dedicates one hydraulic pump to travel and one to the attachment on a continuous basis, allowing for a smooth and constant movement speed even while swinging or using the boom or attachment. With Independent Travel, safely carrying a large pipe across a job site is a breeze.

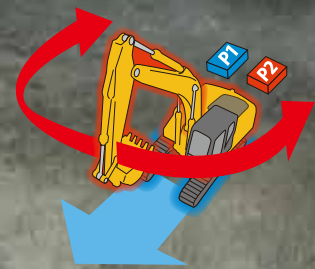

Swing Priority

Our exclusive system automatically and instantly delivers full swing power during combined operations. There's no need to switch modes to make quick work of jobs like side-digging and back-filling.

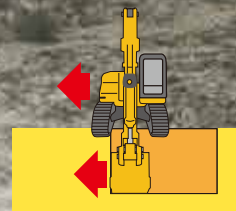

Power Boost

When you need more power instantly, engage Power Boost to get 10% more power with no time limit.

■ Max. Bucket Digging Force (SAE)

With Power Boost: **41,100 lbs {183 kN}**

■ Max. Arm Crowding Force (SAE)

With Power Boost: **30,100 lbs {134 kN}**



SAFETY ON FULL DISPLAY

Standard 3 Sides Safety Camera System

Our high-resolution, large display shows right, left and rear side cameras together. Multiple display allows the operator to customize viewing needs to enhance operator awareness and jobsite safety.



Large 10-Inch Color Monitor

The easy-to-operate menu screen and recognizable icons assist the operator to select the most important information needed to ensure jobsite safety and machine control.



Dial in the Right Information

Simply turn the jog dial to the right or left to select an operational feature, then press the dial to confirm selection.





PREMIER OPERATOR COMFORTS

Heated Air Ride Suspension Seat

A 7-way adjustable seat achieves excellent shock absorption and superior ride comfort.

Multi Vent Air Conditioner

Cool air is blown from multiple outlets toward the operator's body for more comfortable operation.

Ergonomic Lever Angles

Operators can move levers horizontally without twisting their wrists, reducing fatigue.



Adjustable Height Joysticks

Joystick height is manually adjustable to suit operator's preference.

LED Interior Light

Interior lights turn on and off automatically when the door is open or the ignition is turned to the OFF position. This ensures safe entry and exit in the dark.

Tilting Left Side Console

Flip-up left console with integrated pilot control lock lever tilts for easy entry and exit from the cab.



THE ULTIMATE IN SIMPLE DESIGN

In our pursuit of functional beauty and styling, we created an all new interior design focused with the operator in mind.

Jog Dial

This dial integrates multiple functions into a single, easy to use interface. Even with gloves on, the operator can make the adjustments they need.

LED Illumination

Dials and buttons are now backlit to provide a bright, clear view in any lighting condition.



EASY MAINTENANCE



SAFETY AND CONVENIENCE IN EVERY CORNER



Standard Overhead Top Guard Level II
The standard overhead cab guard can be tilted open with gas damper for easy window cleaning. Meets standard top guard level II requirements. (ISO 10262)



Two-Stage Air Filter
Provides superior cleaning and engine protection.



Ground level DEF tank



Control valve
Cleanly mounted with easy access to test ports.



Ground level storage compartment access



Right Side (Ground Level Maintenance)
Hydraulic pump and engine filter compartment.



Fuel filters
Main Filter / Pre-Filter with Integrated Water Separator.



Engine Oil Filter
Remote mounted for easy maintenance.



Rear camera

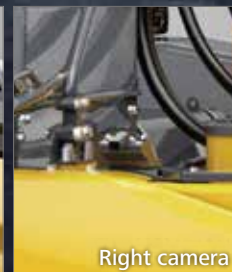

Right camera



Left camera

Standard Rear, Left and Right Side Cameras



Swing Flashers for a Safer Jobsite

Standard swing flashers notify ground workers that the machine is swinging.



Travel Alarm



Seatbelt Unfastened Indicator On Monitor

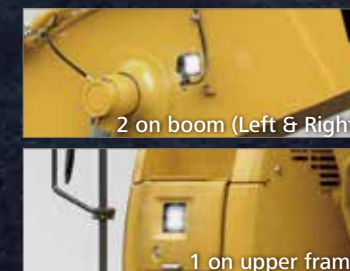

2 on boom (Left & Right)

1 on upper frame

Standard 7 LED Lights

Bright LED lights ensure visibility even during night work.



2 on counterweight

2 on cab top front



Wire Mesh or Vertical Bar Front Cab Guard (optional)



Battery Disconnect Switch with DEF Purge Notification Buzzer



Arm

Bucket link

Machine Guidance Ready Brackets

Pre-welded brackets for quicker and easier installation of Machine Guidance Systems.



Boom

Counterweight

Quick Coupler Piping Brackets



Adjustable Height Joystick Consoles
The operator can adjust height of attachment control levers.



Hands-Free Bluetooth® Phone Calls



USB Charging Port / 12V Power Outlet



Smartphone Holder
Includes USB port for charging.

Specifications

Engine

Model	ISUZU 6HK1
Type	Direct injection, water-cooled, 4-cycle diesel engine with turbocharger, intercooler, Tier IV Final certified
No. of cylinders	6
Bore and stroke	4.5" x 4.9" { 115mm x 125 mm }
Displacement	475.4 cu.in { 7,790 ml }
Rated power output	265hp {198 kW} /1,900 rpm (SAE NET) 282hp {210 kW} /1,900 rpm (Without fan)
Max. torque	745 lb-ft {1,011N·m} / 1,500rpm (SAE NET) 797 lb-ft {1,080N·m} / 1,500rpm (Without fan)

Hydraulic System

Pump	
Type	Two variable displacement pumps + one gear pump
Max. discharge flow	2 x 64.7 gpm { 2 x 245L/min } 1 x 5.0 gpm { 1 x 19 L/min }
Relief valve setting	
Boom, arm and bucket	4,970 psi {34.3 MPa}
Power Boost	5,480 psi {37.8 MPa}
Travel circuit	4,970 psi {34.3 MPa}
Swing circuit	4,210 psi {29.0 MPa}
Control circuit	725 psi {5.0 MPa}
Pilot control pump	Gear type
Main control valve	8-spool
Oil cooler	Air cooled type

Swing System

Swing motor	Axial piston motor
Brake	Hydraulic; locking automatically when the swing control lever is in the neutral position
Parking brake	Oil disk brake, hydraulic operated automatically
Swing speed	8.4 rpm
Swing torque	90,100 lb-ft { 122.1 kN·m }

Hydraulic P.T.O.

Specification	Output	Maximum pressure psi {MPa}	Max. flow U.S. gpm, {lpm}
			(0 pressure) 1,900 rpm
Auxiliary		4,970 {34.3}	2 x 64.7 {2 x 245}
Rotation		3,263 {22.5}	11.7 {44.3}

Operating Weight & Ground Pressure

In standard trim, with standard boom, 10'2" {3.10 m} arm, and 1.57 cu.yd. {1.20 m³} ISO heaped bucket

Shaped		Single grouser shoes (even height)	Triple grouser shoes (even height)	
shoe width	ft-in {mm}	31.5" {800}	31.5" {800}	33.5" {850}
overall width of crawler	ft-in {mm}	11'1" {3,390}	11'1" {3,390}	11'3" {3,440}
operation weight	lb {kg}	83,600 {37,900}	84,200 {38,200}	84,700 {38,400}
Ground pressure	psi {kPa}	7.7 {53}	7.8 {54}	7.4 {51}

Travel System

Travel motors	2 x axial-piston, two-step motors
Travel brakes	Hydraulic brake per motor
Parking brakes	Oil disc brake per motor
Travel shoes	48 each side
Travel speed	2.8/1.7 mph {4.6/2.9 km/h}
Drawbar pulling force	70,500 lb {314 kN}
Gradeability	70% {35°}

Cab & Control

Cab
All-weather, sound-suppressed steel cab mounted on silicon-sealed viscous mounts and equipped with a heavy, insulated floor mat.
Control
Two hand levers and two foot pedals for travel
Two hand levers for excavating and swing
Electric rotary-type engine throttle

Boom, Arm & Bucket

Boom cylinders	5.7" {145 mm} x 4'6" {1,361 mm}
Arm cylinder	5.9" {150 mm} x 5'6" {1,675 mm}
Bucket cylinder	5.1" {130 mm} x 4'0" {1,208 mm}

Refilling Capacities & Lubrications

Fuel tank	92.5 U.S.gal {350 L}
Cooling system	10.9 U.S.gal {41 L}
Engine oil	12.8 U.S.gal {48.6 L}
Travel reduction gear	2 x 2.0 U.S.gal {2 x 7.5 L}
Swing reduction gear	2.0 U.S.gal {7.4 L}
Hydraulic oil tank	64.7 U.S.gal {245 L}: Tank oil level 116.2 U.S.gal {440 L}: Hydraulic system
DEF tank	5.5 U.S.gal {21 L}

Working Ranges

Unit: ft-in {m}

Boom	20'4" { 6.20 m }	
	Arm	Standard 10'2" { 3.10 m }
a- Max. digging reach	35'10" { 10.93 }	37'9" { 11.50 }
b- Max. digging reach at ground level	35'3" { 10.74 }	37'2" { 11.32 }
c- Max. digging depth	22'11" { 6.99 }	24'9" { 7.55 }
d- Max. digging height	36'8" { 11.17 }	38'3" { 11.66 }
e- Max. dumping clearance	26'9" { 8.15 }	28'3" { 8.61 }
f- Min. dumping clearance	10'2" { 3.11 }	8'5" { 2.57 }
g- Max. vertical wall digging depth	20'1" { 6.11 }	22'5" { 6.84 }
h- Min. swing radius	11'4" { 3.45 }	11'7" { 3.53 }
i- Horizontal digging stroke at ground level	18'4" { 5.59 }	20'9" { 6.32 }
j- Digging depth for 8' {2.4 m} flat bottom	22'5" { 6.83 }	24'3" { 7.40 }
Bucket capacity SAE heaped cu.yd. {m ³ }	1.57 { 1.20 }	1.57 { 1.20 }

Digging Force (ISO 6015)

Unit: lb {kN}

Arm length	Standard 10'2" { 3.10 m }		Long 12'0" { 3.65 m }		
	Bucket digging force	SAE 37,300 { 166 }	41,100 { 183 }*	ISO 42,500 { 189 }	46,800 { 208 }*
Arm crowding force	SAE	27,400 { 122 }	30,100 { 134 }*	24,500 { 109 }	27,000 { 120 }*
	ISO	28,300 { 126 }	31,200 { 139 }*	25,600 { 114 }	28,100 { 125 }*

*Power Boost engaged.

Dimensions

Unit: ft-in {mm}

Arm length	Standard 10'2" { 3.10 m }		Long 12'0" { 3.65 m }	
	A Overall length	32'9" {9,980}	33'1" {10,090}	
B Overall height (to top of boom)	10'11" {3,320}	12'2" {3,710}		
C Overall width**	11'3" {3,440}			
D Overall height (to top of muffler guard)	11'9" {3,580}			
E Ground clearance of rear end*	3'10" {1,160}			
F Ground clearance*	19.1" { 485 }			
G Tail swing radius	6'3" {1,900}			
G' Distance from center of swing to rear end	6'3" {1,900}			

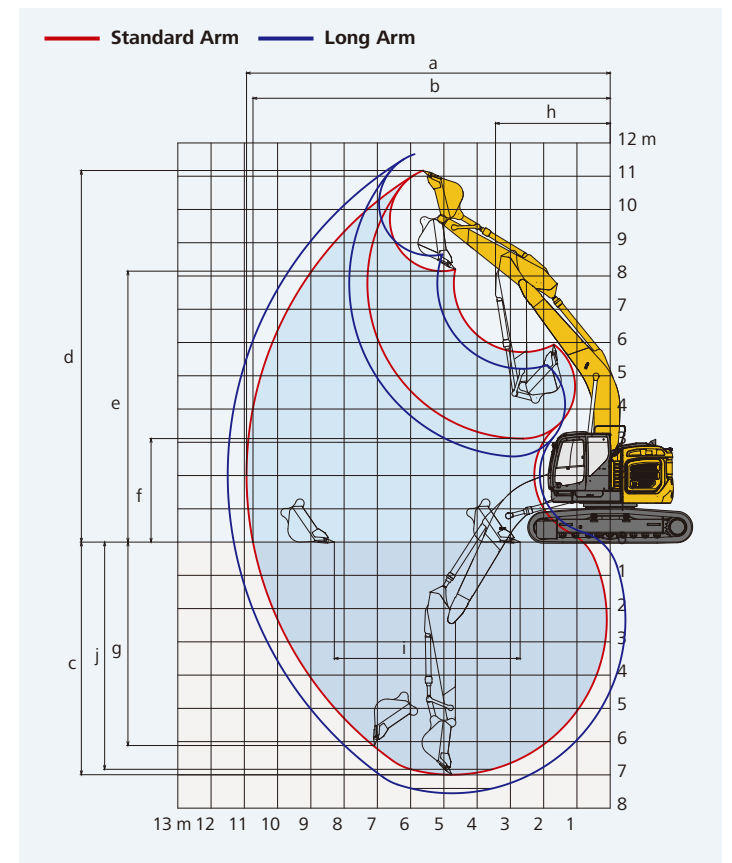

H Tumbler distance	13'3" {4,050}
I Overall length of crawler	16'3" {4,960}
J Track gauge	8'6" {2,590}
K Shoe width	33.5" { 850 }
L Overall width of upperstructure	10'5" {3,180}

*Without including height of shoe lug.
**Shoe width: 33.5" { 850 mm }

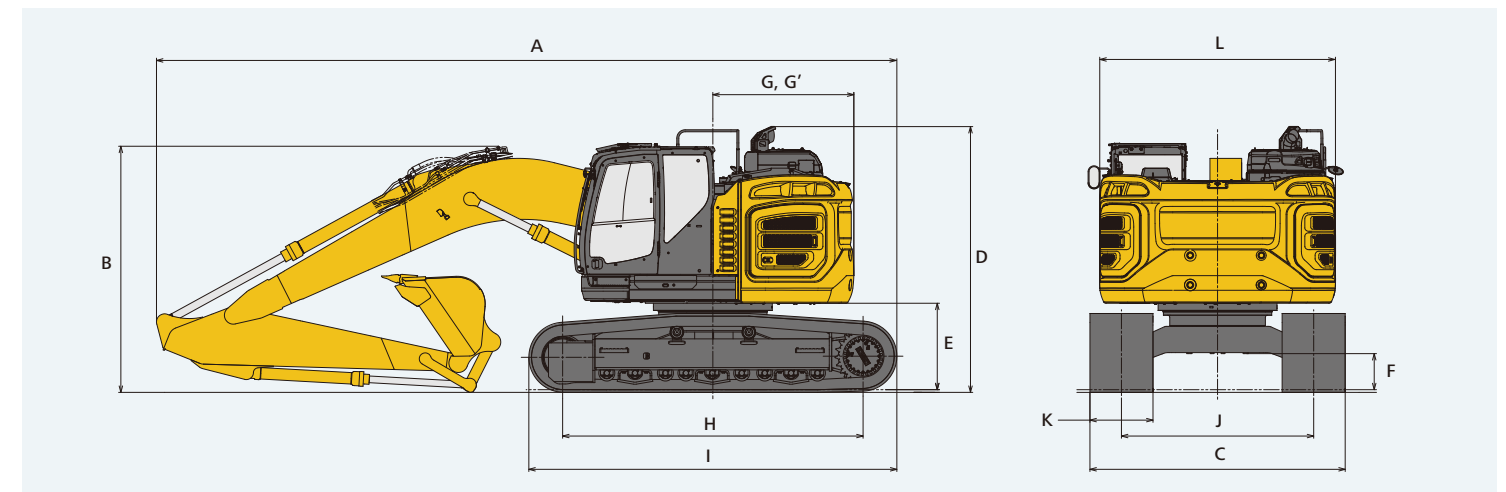

Lift Capacities

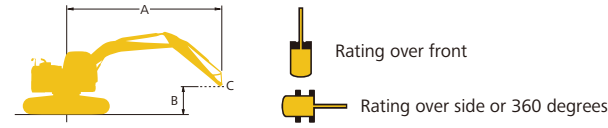

A - Reach from swing centerline to arm top
 B - Arm top height above/below ground
 C - Lift point
 Relief valve setting {Heavy Lift}: 5,480 psi {37.8 MPa}

SK380SRLC		Boom: 20'4" (6.20 m)		Arm: 10'2" (3.10 m)		Bucket: Without		Counterweight: 19,600 lb (8,900 kg)		Shoes: 33.5" (850 mm) (Heavy Lift)				
		10'0" (3.0m)		15'0" (4.6m)		20'0" (6.1m)		25'0" (7.6m)		30'0" (9.1m)		At max. reach		
		Rating over front		Rating over side or 360 degrees		Rating over front		Rating over side or 360 degrees		Rating over front		Radius		
30'0" (9.1m)	lb (kg)											*10,770 (4,880)	*10,770 (4,880)	19'44" (5.92m)
25'0" (7.6m)	lb (kg)											*9,430 (4,270)	*9,430 (4,270)	24'43" (7.44m)
20'0" (6.1m)	lb (kg)											*8,910 (4,040)	*8,910 (4,040)	27'60" (8.41m)
15'0" (4.6m)	lb (kg)	*35,650 (16,170)	*35,650 (16,170)	*24,340 (11,040)	*24,340 (11,040)	*19,960 (9,050)	18,520 (8,400)	*17,770 (8,060)	13,110 (5,940)			*8,810 (3,990)	*8,810 (3,990)	29'56" (9.00m)
10'0" (3.0m)	lb (kg)			*31,570 (14,310)	26,400 (11,970)	*23,250 (10,540)	17,420 (7,900)	*19,350 (8,770)	12,570 (5,700)	*12,500 (5,660)	9,490 (4,300)	*9,020 (4,090)	*9,020 (4,090)	30'56" (9.31m)
5'0" (1.5m)	lb (kg)			*36,870 (16,720)	24,480 (11,100)	*26,150 (11,860)	16,440 (7,450)	20,160 (9,140)	12,040 (5,460)	*14,350 (6,500)	9,250 (4,190)	*9,550 (4,330)	8,950 (4,050)	30'69" (9.35m)
G.L.	lb (kg)			*38,480 (17,450)	23,660 (10,730)	27,540 (12,490)	15,800 (7,160)	19,740 (8,950)	11,660 (5,280)			*10,530 (4,770)	9,110 (4,130)	29'96" (9.13m)
-5'0" (-1.5m)	lb (kg)	*25,840 (11,720)	*25,840 (11,720)	*37,390 (16,950)	23,500 (10,650)	27,240 (12,350)	15,540 (7,040)	19,560 (8,870)	11,500 (5,210)			*12,230 (5,540)	9,800 (4,440)	28'31" (8.62m)
-10'0" (-3.0m)	lb (kg)	*40,830 (18,520)	*40,830 (18,520)	*34,080 (15,450)	23,760 (10,770)	*25,660 (11,630)	15,640 (7,090)	*19,240 (8,720)	11,660 (5,280)			*15,500 (7,030)	11,370 (5,150)	25'55" (7.78m)
-15'0" (-4.6m)	lb (kg)	*37,460 (16,990)	*37,460 (16,990)	*27,700 (12,560)	24,460 (11,090)	*20,170 (9,140)	16,200 (7,340)					*18,090 (8,200)	15,020 (6,810)	21'24" (6.47m)

SK380SRLC		Boom: 20'4" (6.20 m)		Arm: 12'0" (3.65 m)		Bucket: Without		Counterweight: 19,600 lb (8,900 kg)		Shoes: 33.5" (850 mm) (Heavy Lift)						
		5'0" (1.5m)		10'0" (3.0m)		15'0" (4.6m)		20'0" (6.1m)		25'0" (7.6m)		30'0" (9.1m)		At max. reach		
		Rating over front		Rating over side or 360 degrees		Rating over front		Rating over side or 360 degrees		Rating over front		Rating over side or 360 degrees		Radius		
30'0" (9.1m)	lb (kg)													*9,170 (4,150)	*9,170 (4,150)	22'32" (6.80m)
25'0" (7.6m)	lb (kg)													*8,130 (3,680)	*8,130 (3,680)	26'75" (8.15m)
20'0" (6.1m)	lb (kg)													*7,680 (3,480)	*7,680 (3,480)	29'66" (9.04m)
15'0" (4.6m)	lb (kg)													*7,550 (3,420)	*7,550 (3,420)	31'49" (9.59m)
10'0" (3.0m)	lb (kg)													*7,660 (3,470)	*7,660 (3,470)	32'43" (9.88m)
5'0" (1.5m)	lb (kg)													*8,030 (3,640)	7,980 (3,610)	32'55" (9.92m)
G.L.	lb (kg)			*13,710 (6,210)	*13,710 (6,210)	*37,590 (17,050)	23,360 (10,590)	*26,870 (12,180)	15,550 (7,050)	19,500 (8,840)	11,410 (5,170)	14,940 (6,770)	8,820 (4,000)	*8,710 (3,950)	8,090 (3,660)	31'87" (9.71m)
-5'0" (-1.5m)	lb (kg)	*15,500 (7,030)	*15,500 (7,030)	*23,030 (10,440)	*23,030 (10,440)	*37,550 (17,030)	22,960 (10,410)	26,860 (12,180)	15,160 (6,870)	19,210 (8,710)	11,150 (5,050)	*12,440 (5,640)	8,740 (3,960)	*9,880 (4,480)	8,630 (3,910)	30'33" (9.24m)
-10'0" (-3.0m)	lb (kg)	*25,210 (11,430)	*25,210 (11,430)	*34,930 (15,840)	*34,930 (15,840)	*35,170 (15,950)	23,070 (10,460)	*26,180 (11,870)	15,130 (6,860)	19,230 (8,720)	11,170 (5,060)			*11,970 (5,420)	9,800 (4,440)	27'78" (8.46m)
-15'0" (-4.6m)	lb (kg)			*42,100 (19,090)	*42,100 (19,090)	*30,090 (13,640)	23,630 (10,710)	*22,350 (10,130)	15,510 (7,030)					*16,440 (7,450)	12,340 (5,590)	23'89" (7.28m)

- Note:
- Do not attempt to lift or hold any load that is greater than these lift capacities at their specified lift point radius and heights. Weight of all accessories must be deducted from the above lift capacities.
 - Lift capacities are based on machine standing on level, firm, and uniform ground. User must make allowance for job conditions such as soft or uneven ground, out of level conditions, side loads, sudden stopping of loads, hazardous conditions, experience of personnel, etc.
 - Bucket pin attachment point defined as lift point.
 - The above lift capacities are in compliance with ISO 10567. They do not exceed 87% of hydraulic lift capacity or 75% of tipping load. Lift capacities marked with an asterisk (*) are limited by hydraulic capacity rather than tipping load.
 - Operator should be fully acquainted with the Operator's and Maintenance Instructions before operating this machine. Rules for safe operation of equipment should be adhered to at all times.
 - Lift capacities apply to only machine as originally manufactured and normally equipped by KOBELCO CONSTRUCTION MACHINERY CO., LTD.



Total Support for Machines with Network Speed and Accuracy

KOMEXS is a telematics system for receiving machine information. Manage your machines anywhere in the world using the Internet. Location, workload and diagnostic data aid business operations.



Direct Access to Operational Status

Location Data

Accurate location data can be obtained even from sites where communications are difficult.



Latest location

Fuel Consumption Data

Data on fuel consumption and idling times can be used to indicate improvements in fuel consumption.

Work mode	Working Hrs	Total Fuel Consumption
H mode	2:06	24.5 L
S mode	0:00	0.0 L
E mode	169:19	1489.7 L
TOTAL	171:25	1514.2 L

Fuel consumption

Operating Hours

A comparison of operating times of machines at multiple locations shows which locations are busier and more profitable. Operating hours on site can be accurately recorded, for running time calculations needed for rental machines, etc.

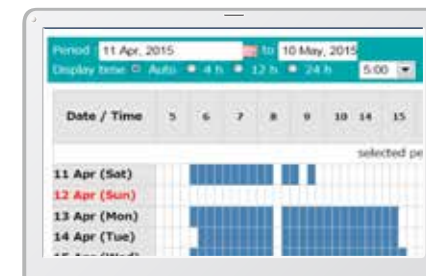

Daily report

Graph of Work Content

The graph shows how working hours are divided among different operating categories, including digging, idling, traveling, and optional operations (NGB).

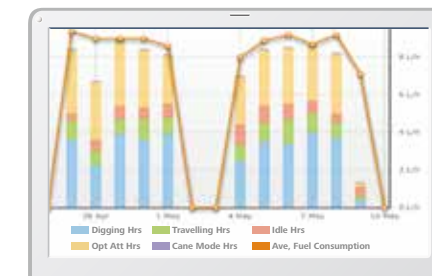

Work status

Maintenance Data and Warning Alerts

Machine Maintenance Data

Provides maintenance status of separate machines operating at multiple sites. Maintenance data is also relayed to KOBELCO service personnel, for more efficient planning of periodic servicing.

Model	Serial No.	Hour Meter	Engine Oil	F
SK135SRLC	YH07-09721	734 hr		434 hr
3/SK140SRLC	0.38/0.35	73 hr		429 hr
SK135SRLC	YH07-09789			
3/SK140SRLC	0.38/0.35			
SK210LC-9	YQ12-10458	960 hr		58 hr
	0.8/0.7			
SK210LC-9	YQ12-10481	549 hr		498 hr
	0.8/0.7			
SK759R	YT08-30374			

Warning Alerts

This system warns an alert if an anomaly is sensed, preventing damage that could result in machine downtime.

Security System

Engine Start Alarm

Sends a notification if the engine is started outside of pre-defined hours.

Area Alarm

Sends a notification if the machine leaves a pre-defined area.