

## STANDARD EQUIPMENT

### ENGINE

- Engine, HINO P11C-VN, Diesel engine with turbocharger and intercooler, Tier IV final certified
- Automatic engine deceleration
- Batteries (2 x 12V - 176Ah)
- Starting motor (24V - 5 kW), 60 amp alternator
- Removable clean-out screen for radiator
- Automatic engine shut-down for low engine oil pressure
- Engine oil pan drain cock
- Double element air cleaner
- Hydraulic driven cooling fan

### CONTROL

- Working mode selector (H-mode, S-mode and ECO-mode)
- Heavy Lift and Power Boost "without time limit"

### SWING SYSTEM & TRAVEL SYSTEM

- Swing rebound prevention system
- Straight propel system
- Independent travel system
- Two-speed travel with automatic down shift
- Sealed & lubricated track links
- 35.4" {900mm} track shoes
- Grease-type track adjusters
- Automatic swing brake
- Lower track guards
- Eight lower track guards

### HYDRAULIC

- Exclusive boom to arm regeneration systems
- Independent hydraulic driven cooling fan for oil cooler
- Auto warm up system
- Aluminum hydraulic oil cooler

### MIRRORS & LIGHTS

- Three rearview mirrors plus rear-view camera
- Two front working lights for boom and one front working light for upper structure
- Swing flashers and rear work lights

### CAB & CONTROL

- ROPS cab
- Two control levers, pilot-operated
- Horn, electric
- Integrated left-right slide-type control box
- All-weather, sound suppressed cab
- Interior cab light
- Cab mirror
- Coat hook
- Luggage tray
- Large cup holder
- Detachable two-piece floor mat
- 7-way adjustable suspension seat
- Headrest
- Handrails
- Heater and defroster
- Intermittent windshield wiper with double-spray washer
- Skylight
- Top guard
- Tinted safety glass
- Pull-type front window and removable lower front window
- Easy-to-read multi-display monitor
- Automatic air conditioner
- Emergency escape hammer
- Travel alarm
- Attachment pressure release switch
- Manual DPF switch
- 12V converter
- DEF level gauge

## OPTIONAL EQUIPMENT

- Single grouser shoes
- Boom & arm load (lock) holding valve
- Front-guard protective structures
- Additional hydraulic circuits
- Right view camera
- Various optional arms

- Control pattern changer (2-way)
- Counter weight self removal device
- Air Suspension Seat with Heat
- Cab lights
- Vandal Guards available via KOBELCO Parts department
- ME specification

Note: This document may contain attachments and optional equipment that are not available in your area. It may also contain photographs of machines with specifications that differ from those sold in your area. Please contact your nearest KOBELCO dealer for items you require. Due to our policy of continuous product improvement, all designs and specifications are subject to change without advance notice. Copyright KOBELCO CONSTRUCTION MACHINERY CO., LTD. No part of this document may be reproduced in any manner without prior written permission from KOBELCO.

## KOBELCO CONSTRUCTION MACHINERY U.S.A. INC.

22350 Merchants Way, Katy, Texas 77449  
<http://www.kobelco-usa.com/>

Inquiries To:

Bulletin No. SK500LC-NA-101-160900N

# KOBELCO

Hydraulic Excavator

# SK500 LC

SK500LC-10

## DRIVEN BY PASSION

■ Bucket Capacity :

1.5 - 4.26 cu yd SAE

■ Engine Power :

369 hp {271 kW}/1,850 rpm  
(SAE NET)

■ Operating Weight :

114,000 lbs {51,700 kg}



Complies with the latest exhaust emission regulations



US EPA  
Tier IV Final



EU (NRMM)  
Stage IV



Japanese  
Regulations

# Power Meets Efficiency

Increased POWER  
means increased  
PRODUCTIVITY

Greater fuel  
economy means  
higher efficiency

From urban centers to mines around the world, KOBELCO's all-out innovation brings you durable, Earth-friendly construction machinery that's equal to any task all over the planet. Increased power and better fuel economy bring greater efficiency to any project. KOBELCO SK500LC conventional excavators are more durable than ever, able to withstand the rigors of the toughest job sites.

Focusing on the global environment of the future, KOBELCO offers next-generation productivity to meet the need for lower life cycle costs and exceed the expectations of customers the world over. It all adds up to new levels of value that are a step ahead of the times.



## SK500<sub>LC</sub>

# More Power and Higher Efficiency

The highly efficient hydraulic system minimizes fuel consumption while maximizing power. With nimble movement and outstanding digging power, this excavator improves job productivity.

↑  
About **11%** increase  
■ Digging volume/hour  
(Compared to S-mode on previous models)

**S** S-mode...About **11%** improvement  
**H** H-mode...About **10%** improvement



## Power to do more, faster

### Digging Volume

The SK500LC offers dynamic digging force even as it minimizes fuel consumption, achieving class-leading work volume. S-mode boasts increased torque, delivering 11% greater digging volume than previous model (SK500LC-9).

### Heavy Lift

11% more hydraulic pressure (Heavy Lift) means greater lifting power with no time limit, for smooth and steady operation while moving heavy objects.

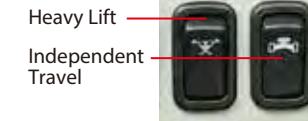

### Independent Travel

Selecting Independent Travel dedicates one hydraulic pump to travel, allowing for a smooth and constant movement speed even while swinging or using the boom or attachment. With Independent Travel, safely carrying a large pipe across a job site is a breeze.

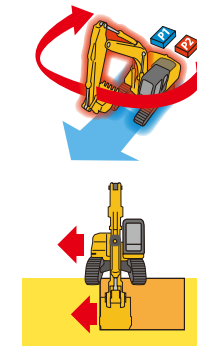

### Swing Priority

Our exclusive system automatically and instantly delivers full swing power during combined operations, making quick work of jobs like side digging and backfilling - no mode-switching

### Power Boost

For extra power, Power Boost gives you 11% more power instantly and for as long as you need it.

- Max. Bucket Digging Force (ISO 6015)  
With Power Boost: **65,600 lbs** (292kN)
- Max. Arm Crowding Force (ISO 6015)  
With Power Boost: **49,900 lbs** (222kN)

### Drawbar Pulling Force

Excellent drawbar force lets you conquer rough terrain and slopes.

**93,300 lbs** (415kN)



## Built to operate in tough working environments

### Hydraulic Drive for Engine Cooling Fan, Independent Oil Cooler Fan NEW

Hydraulic drive optimizes the cooling fan rotation speed to improve fuel economy and reduce noise. Also, the independent oil cooler fan better matches cooling to the hydraulic oil temperature, for optimal oil temperature control.

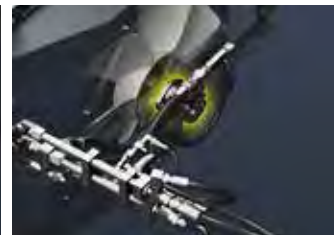

Fan for radiator and inter cooler

Fan for oil cooler

## Conforms to Tier IV Final exhaust emissions standards

### Reduces Fuel Consumption and Minimizes Exhaust Emissions NEW

The HINO engine, (a subsidiary of Toyota) is renowned for fuel efficiency and environmental performance, and KOBELCO has tuned them specifically for construction machinery. The high-pressure common rail fuel injection system, the variable-geometry (VG) turbocharger, reduce particulate matter (PM) while the large EGR cooler greatly reduces the formation of nitrogen oxide (NOx) gases.



#### VG turbo reduces PM

The variable-geometry turbocharger adjusts air intake to maximize combustion efficiency and promotes faster, cleaner response to varying engine load. At low engine speeds the nozzles are closed, the turbo speed increased and air intake is boosted. This helps lower fuel consumption.

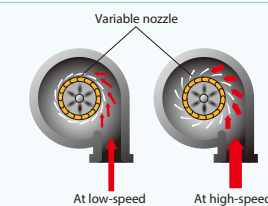

### SCR System with DEF NEW

Engine exhaust system utilizes Selective Catalytic Reduction (SCR) to convert NOx\* into harmless nitrogen and water emissions. SCR combined with a Diesel Particulate Filter (DPF) makes the SK500LC a much cleaner machine.  
\*NOx: Nitrogen Oxide

■ NOx reduction rate  
(Compared to previous models)

About **80%** decrease\*

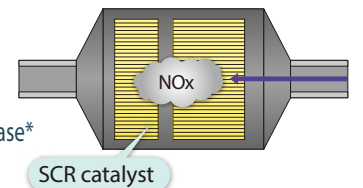

#### EGR cooler reduces NOx

Cooled exhaust gases from the EGR cooler are mixed with fresh air in the intake. The recirculated air lowers the combustion temperature which reduces NOx.

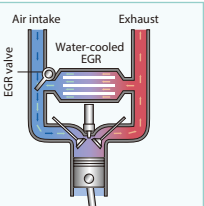

# Evolution Continues, with Improved Fuel Efficiency



## Boom to Arm Regeneration System NEW

Innovative engineering uses the downward movement of the boom to push fluid to the arm. Gravity and kinetic energy greatly reduce the amount of power needed to move fluid through the system.

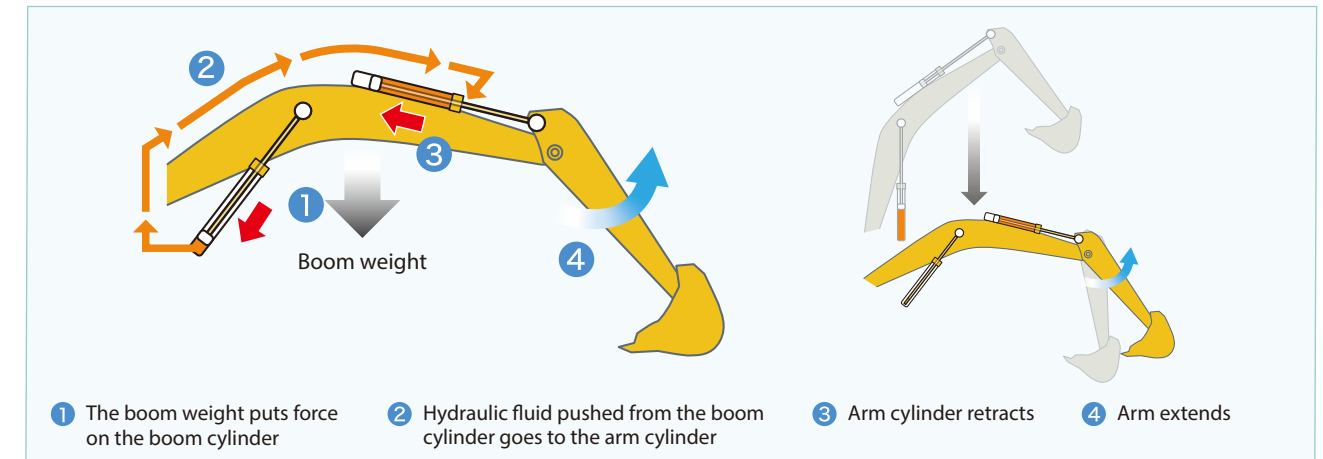

## Hydraulic Circuit Reduces Energy Loss

Improved hydraulic line layout minimizes hydraulic pressure resistance from turbulence and valve restrictions. Fuel efficiency is increased because it takes less energy to move fluid through a circuit with low flow resistance.

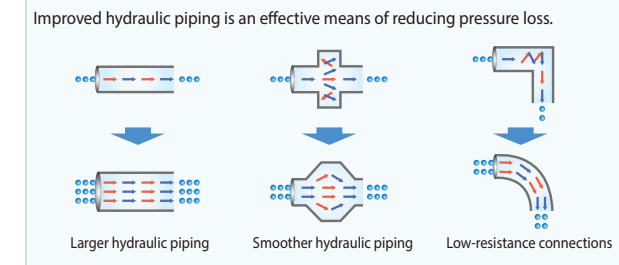

## AIS (Auto Idle Stop)

The engine will stop automatically after 60 seconds (Adjustable) of inactivity if the safety lock lever is in the up position. This eliminates wasteful idling during standby, saving fuel and reducing CO<sub>2</sub> emissions.

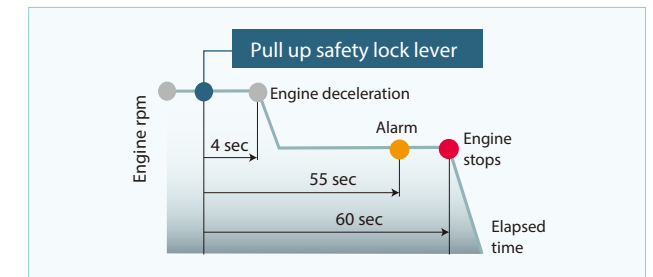

## Counterweight Removal System (Optional)

Designed to reduce weight during transport, this system makes counterweight removal and installation a one-person job, enhancing safety and reducing labor costs and crane rental fee.

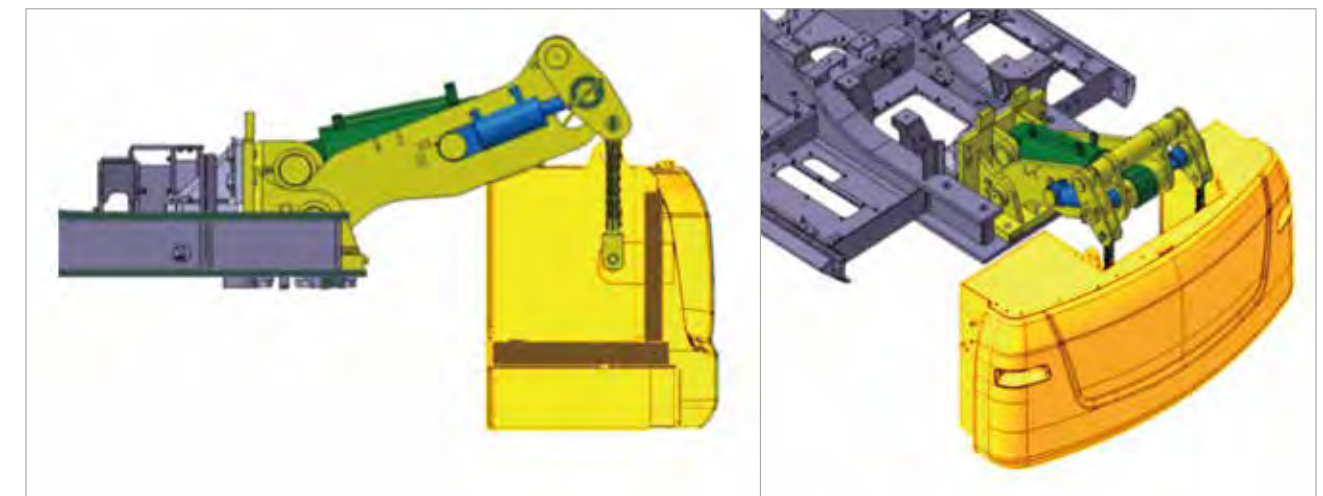

### Revolutionary technology boosts efficiency and minimizes fuel consumption

#### Operation Mode

■ Optimal operation with three modes

**H** H-mode ••• Maximum power for maximum productivity on your toughest jobs

**S** S-mode ••• Ideal balance of productivity and fuel efficiency for a range of urban engineering projects

**E** ECO-mode ••• Minimum fuel consumption for utility projects and other work that demands precision

Improved fuel economy in ECO-modes.

■ Compared to previous models (SK500LC-9, ECO-mode)

**E** ECO-mode ••• About **5%** improvement

Always and Forever. Yesterday, Today, and Tomorrow. We're Obsessed with Fuel Efficiency.

Over the past 10 years, KOBELCO has achieved an average fuel consumption reduction of 36% across its fleet. We vow to lead the industry in improving fuel efficiency.

■ Compared to SK485LC-6 model (2006)

**E** ECO-mode (SK500LC-10) ••• About **31%** improvement

# Increased Power with Enhanced Durability to Maintain the Machine's Value

Smart system design increases strength and eliminates hydraulic problems. Enhanced POWER, reliability, and durability takes productivity to a new level.



## Improved filtration system reliability

Clean, contaminant-free fuel and hydraulic fluid are essential to stable performance. The improved filtration systems reduce the risk of mechanical trouble and enhance longevity and durability.

### Increased Filtering Capacity for Hydraulic Oil

NEW

Two filters installed for returning hydraulic oil, to curb clogging and increase the durability and reliability of the hydraulic equipment. Filtering capacity 1.8 times greater than previous model (Generation-9)



### Hydraulic Fluid Filter

NEW

Recognized as the best in the industry, our super-fine filter separates out even the smallest particles. A new cover prevents contamination when changing filters.

Long-life hydraulic fluid:  
5,000 hours

Hydraulic fluid filter replacement cycle is  
1,000 hours



### 500 Hour Attachment Lubrication Interval

Self-lubricating bushings are used at the attachment pins and the bushings with high abrasion resistance are used on the pins around the bucket. The lubrication cycle of the lubrication points around the bucket is 250 hours and that of other lubrication points is 500 hours.



\* Additionally the two-piece bucket bushings protect the side of the arm from contact and then wear from the bucket ears. Should the bucket bushings need replacement, they can be replaced separately from the larger main bushing, reducing costs.

### Four Track Guides

Four heavy-duty track guides installed on each crawler side frame assure stability in the most demanding situations.



### Fuel Filter

NEW

Pre-filter with built-in water-separator has 1.6 times more filter area compared to previous models, with a new final stage to maximize filtering performance.

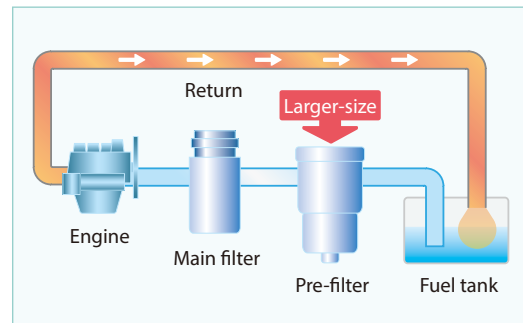

### Hydraulic Fluid Filter Restriction Indicator

NEW

Pressure sensors at the inlet and outlet of the hydraulic oil filter monitor pressure difference to assess the degree of clogging. If the pressure difference exceeds a set level, a warning appears on the multi-display, so the filter can be cleaned before contamination reaches the hydraulic oil tank.

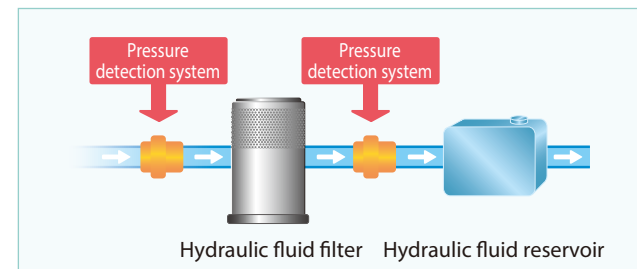

### Angle Guard

This standard safety feature reduces the impact on the excavator in the unlikely event of a collision during swing operation.



### Protective Lower Undercover

The undercover attached to the lower frame protects the hydraulic piping and equipment from flying rocks, bits of rebar, and other debris.



# Comprehensive Safety and Intuitive Operation

User-friendly design and enhanced safety means greater efficiency and productivity.



## Safety

### ROPS / FOPS Cab

ROPS (Roll-Over-Protective Structure)-compliant cab complies with ISO standards (ISO-12117-2: 2008) and ensures greater operator safety in the event of a roll-over. KOBELCO encourages operators to wear their seat belt during operation.



Standard FOPS, Top Guard Level II. (Meets ISO10262)



Mounting brackets for vandalism guards are standard equipment (contact your KOBELCO dealer to fit vandalism or front rock guards).

### Expanded Field of View for Greater Safety



Left and right rear-view mirrors/Right bottom clearance mirror



Rear View Camera

Rear

### Optional right side camera

NEW



Standard rear swing flashers and rear work lights.

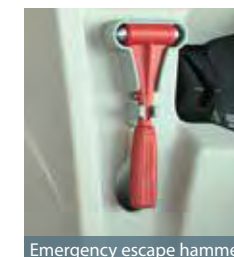

Emergency escape hammer

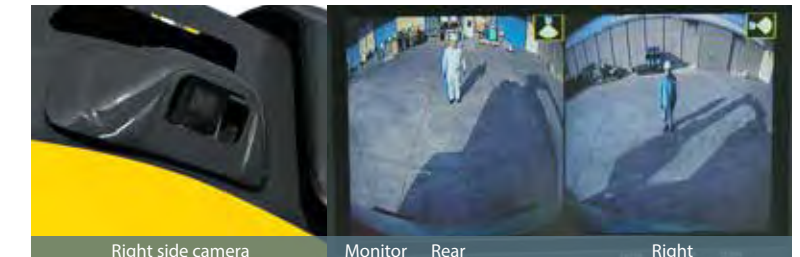

Right side camera

Monitor

Rear

Right

## Operator-friendly features that are easy to see, easy to use



### Color Multi-display

Brilliant colors differentiate multiple graphics on cab LCD. Graphics indicate fuel consumption, maintenance intervals and more.

- 1 Analog-style gauges provide an intuitive reading of fuel level and engine temperature
- 2 Green indicates efficient operation in other modes
- 3 PM accumulation (left)/DEF level (right)
- 4 Fuel consumption/Rear-view camera
- 5 Digging mode switch
- 6 Monitor display switch

### One-touch Attachment Mode Switch

A simple flick of switch converts the hydraulic circuit and flow amount to match attachments. Helpful icons let the operator confirm the proper configuration at a glance.



PM accumulation/DEF level

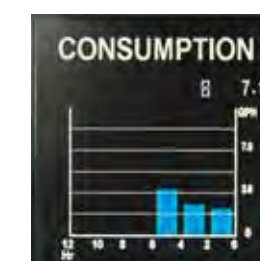

Fuel consumption

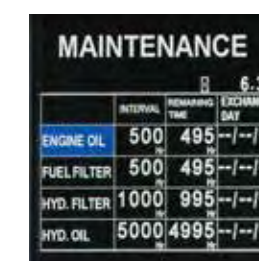

Maintenance



Breaker mode



Nibbler mode



Independent travel mode



Heavy lift

# Cab Comfort Takes a Step Ahead

The newly refined cab puts the operator first, ensuring a quieter, more comfortable work environment and easier operation.



Standard suspension seat



## Comfort

Climate Control Outlets behind the Seat NEW



Five air outlets deliver warm or cool air directly to the operator.

A Light Touch on the Lever Means Smoother, Less Tiring Work NEW



It takes 25% less effort to work the operation lever, which reduces fatigue over long working hours or continuous operations. \*Compared to SK500LC-9 model

More Comfortable Seat Means Higher Productivity



Suspension seat absorbs vibration

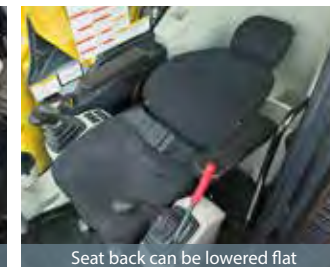

Seat back can be lowered flat



Double slides allow adjustment for optimum comfort

Quiet Inside



The high level of air-tightness ensures a quiet, comfortable cabin interior.

Interior Equipment Adds to Comfort and Convenience

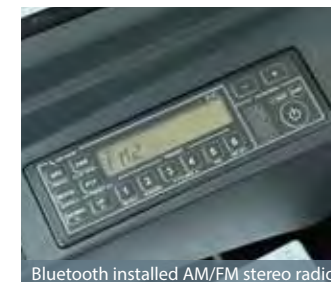

Bluetooth installed AM/FM stereo radio



USB connector/12V power outlet

Large Door Allows Easy Access In and Out of the Cab

The expanded cab provides plenty of room for a large door, more headroom and smoother entry and exit.



Spacious storage tray



Large cup holder

Low Vibration

Coil springs absorb small vibrations and high suspension mounts filled with silicone oil reduce heavy vibration. The long stroke achieved by this system provides excellent vibration protection.

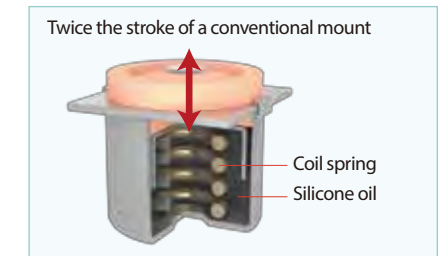

Wide, Open Unobstructed Operator Visibility

The front window features one large piece of glass without a center pillar on the right side for a wide, unobstructed view.

# Efficient Maintenance Keeps the Machine in Peak Operating Condition



MAINTENANCE			
	INTERVAL	REMAINING TIME	EXCHANGE DAY
ENGINE OIL	500	495	--/--
FUEL FILTER	500	495	--/--
HYD. FILTER	1000	995	--/--
HYD. OIL	5000	4995	--/--

6.3h

## Machine information display function

- Displays only the maintenance information that's needed, when it's needed
- Self-diagnostic function provides early-warning detection and display of electrical system malfunctions
- Service-diagnostic function makes it easier to check the status of the machine
- Record function for any possible on going or intermittent service issues

Examples of displaying maintenance information

## Easy, On-the-Spot Maintenance

NEW

There is ample space in the engine compartment for a Service Technician to do maintenance work inside. The distance between steps is lower so entry and exit is easier. And the Service Technician can work in comfort, without contortions or unnatural body positions. Finally, the hood is lighter and easier to raise and lower.

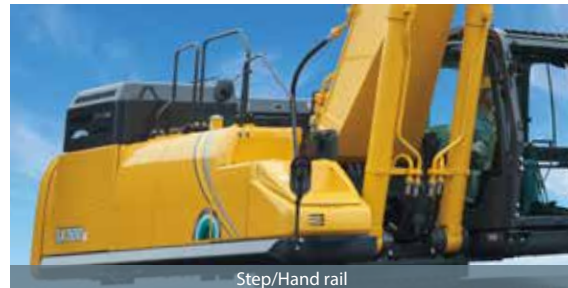

Step/Hand rail



DEF/AdBlue tank



Double-element air cleaner

Located inside the standard machine storage compartment

## Maintenance Work, Daily Checks, Etc., Can Be Done from Ground Level

The layout allows for easy access from the ground for many daily checks and regular maintenance tasks.



Left side



Engine oil filter



Right side



Fuel filter/Pre-fuel filter with integrated water separator

Laid out for easy access to radiator and cooling system elements

1 Engine oil filter 2 Fuel filter with Water separator

## Easy Access to In-cab Maintenance Features



Easy-access fuse box.



DPF Manual Regeneration Switch



Air conditioner filter can be easily removed without tools for cleaning. One for outside air and one for inside air.

## Easy Cleaning



Special sloped crawler side frame design is easily cleaned of mud.

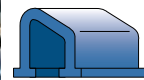

Detachable two-piece floor mat with handles for easy removal.



Fuel tank features bottom flange and large drain valve for easy maintenance.

## Total Support for Machines with Network Speed and Accuracy

KOMEXS is a telematics system for receiving machine information. Manage your machines anywhere in the world using the Internet. Location, workload and diagnostic data aid business operations.

### Direct Access to Operational Status

#### Location Data

Accurate location data can be obtained even from sites where communications are difficult.

#### Operating Hours

A comparison of operating times of machines at multiple locations shows which locations are busier and more profitable. Operating hours on site can be accurately recorded, for running time calculations needed for rental machines, etc.

#### Fuel Consumption Data

Data on fuel consumption and idling times can be used to indicate improvements in fuel consumption.

#### Graph of Work Content

The graph shows how working hours are divided among different operating categories, including digging, idling, traveling, and optional operations (N&B).

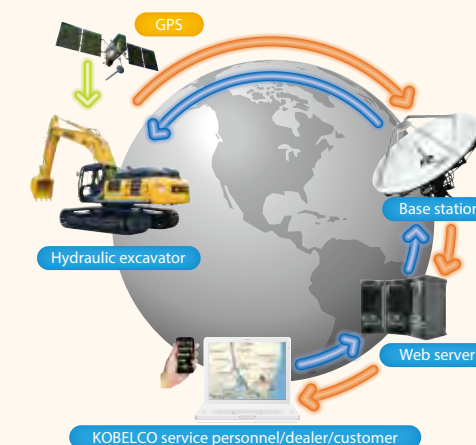

### Maintenance Data and Warning Alerts

#### Machine Maintenance Data

Provides maintenance status of separate machines operating at multiple sites. Maintenance data is also relayed to KOBELCO service personnel, for more efficient planning of periodic servicing.

### Security System

#### Engine Start Alarm

Sends a notification if the engine is started outside of pre-defined hours.

#### Area Alarm

Sends a notification if the machine leaves a pre-defined area.





